

METALMASTER

OPERATION MANUAL



English Wheels Model. EWM-75

Order Code S225

Edition No : EWM-75-1

Date of Issue : 02/2021

www.machineryhouse.com.au

MACHINE DETAILS**MACHINE**

ENGLISH WHEEL

MODEL NO.

EWM-75

SERIAL NO.**DATE OF MANF.**

Distributed by

www.machineryhouse.com.auwww.machineryhouse.co.nz**Note:**

This manual is only for your reference. Owing to the continuous improvement of the Metalmaster machine, changes may be made at any time without obligation or notice. Please ensure the local voltage is the same as listed on the specification plate before operating any electric machine.

**NOTE:**

In order to see the type and model of the machine, please see the specification plate. Usually found on the back of the machine. See example (Fig.1)



Fig.1

CONTENTS:

1. GENERAL MACHINE INFORMATION	
1.1 Specifications.....	4
1.2 Accessories Included.....	4
1.3 Identification.....	5
2. IMPORTANT INFORMATION	
2.1 General Metalworking Machine Safety.....	6
2.2 Specific Safety For English Wheels.....	8
3. SETUP	
3.1 Unpacking.....	9
3.2 Assembly.....	9
4. OPERATION	
4.1 Operation Overview.....	10
4.2 Tracking Patterns.....	11
5. MAINTENANCE	
5.1 Cleaning And Oiling.....	11
Spare Parts.....	12
Risk Assessment Sheets.....	15

1.1 SPECIFICATION

Order Code	S225
MODEL	EWM-75
Operation (Type)	Hand Operated
Mild Steel - Capacity (mm/gauge)	1.6 / 16
Copper - Capacity (mm/gauge)	2.0
Throat Depth (mm)	711
Top Anvil Size (mm)	Ø203 x 50
Radius Dies (mm)	50, 73, 101, 152, 203, 305
Working Height (mm)	1200
Dimensions (L x W x H) (mm)	350 x 90 x 350
Packing Dimensions (L x W x H) (mm)	89 x 77.5 x 18.5
Weight (kg)	73

1.2 ACCESSORIES INCLUDED

Includes 50.8, 76.2, 101.6, 152.4, 203.2, 304.8mm
radius dies & 1 x flat die
Instruction Manual

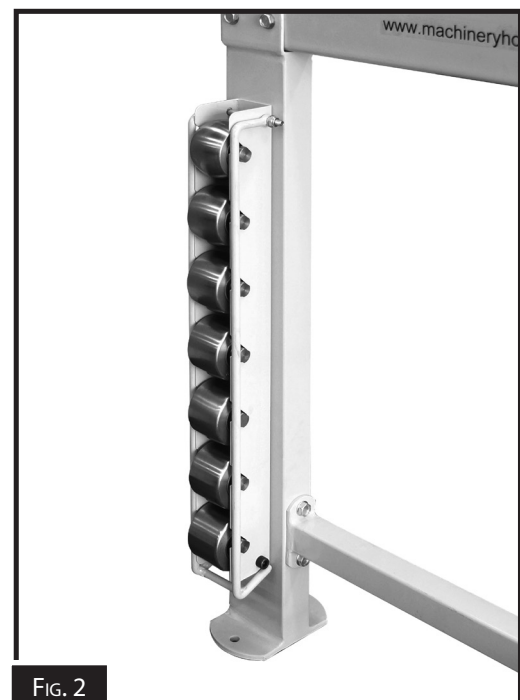

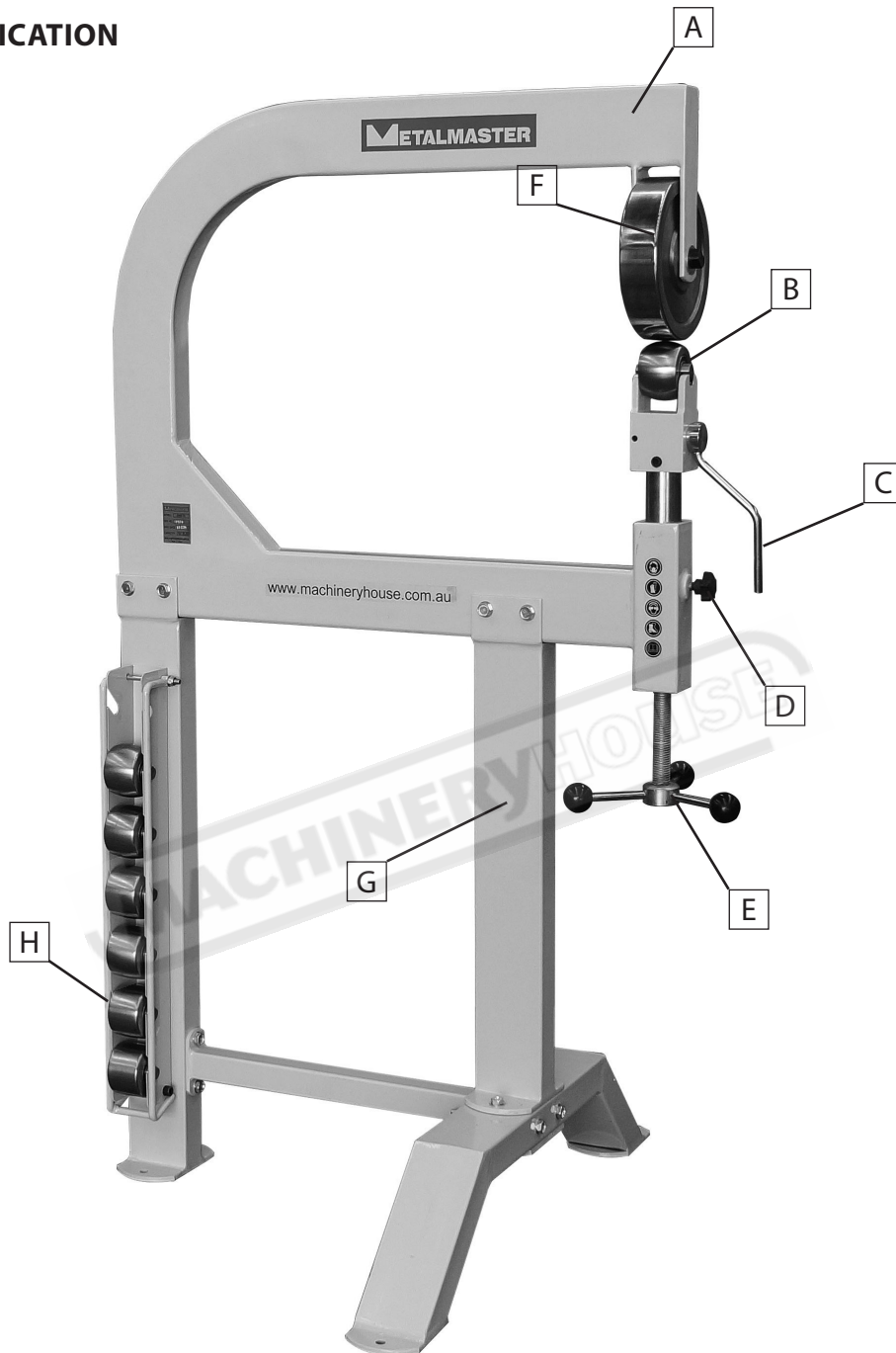
1.3 IDENTIFICATION

A	Main Frame	E	Adjusting Handle
B	Bottom Die	F	Top Die
C	Handle	G	Stand
D	Locking Knob	H	Bottom Die Rack

2.1 GENERAL METALWORKING MACHINE SAFETY



WARNING *When using any tool, basic safety precautions should always be followed to reduce the risk of personal injury and damage. Read the instruction manual before using any tool or machine!*

1. **Keep work area clean.** Cluttered areas invite injuries.
2. **Observe work area conditions.** Do not use machines or power tools in damp or wet locations. Don't expose to rain. Keep the work area well lit. Do not use electric power tools or machinery in the presence of flammable gases or liquids.
3. **Keep children away.** Children must never be allowed in the work area. Do not let them handle machinery, tools, or extension cords.
4. **Store idle equipment.** When not in use, tools must be stored in a dry location to inhibit rust. Always lock up tools and keep out of reach of children.
5. **Do not force tool.** It will do the job better and more safely at the rate for which it was intended. Do not use inappropriate attachments in an attempt to exceed the tool capacity.
6. **Use the right tool for the job.** Do not attempt to force any machine, tool or attachment to do the work of a larger industrial tool. Do not modify, and do not use any tool for a purpose for which it was not intended.
7. **Dress properly.** Do not wear loose clothing or jewelry as they can be caught in moving parts. Protective, electrically non-conductive clothes and non-skid footwear are recommended when working. Wear restrictive hair covering to contain long hair.
8. **Use eye and ear protection.** Always wear ANSI approved impact safety goggles. Wear a full face shield if you are producing metal filings or wood chips. Wear an ANSI approved dust mask or respirator when working around metal, wood, and chemical dusts and mists.
9. **Do not overreach.** Keep proper footing and balance at all times. Do not reach over or across running machines. Keep hands and fingers clear of moving parts.
10. **Maintain tools with care.** Keep tools clean for better and safer performance. Follow the instructions for lubricating and changing accessories. Handles must be kept clean, dry, and free from oil and grease at all times.
11. **Remove adjusting keys and wrenches.** Check that keys and adjusting wrenches are removed from the tool or machine work surface before plugging it in.
12. **Stay alert.** Be attentive and use common sense. Do not operate any machine or tool when you are tired.
13. **Check for damaged parts.** Before using any machine or tool, parts that appears damaged should be carefully checked to determine that it will operate properly and perform its intended function safely. Check for alignment and binding of moving parts. Any broken parts or mounting fixtures, or any other condition that may affect proper operation. Any part that is damaged should be properly repaired or replaced by a qualified technician. Do not use the machine or tool if any switch does not turn on and off properly.

2.1 GENERAL METALWORKING MACHINE SAFETY

14. **Replacement parts and accessories.** When servicing, use only identical replacement parts. The use of any other parts will void the warranty. Only use accessories intended for use with the machine or tool.
15. **Do not operate** machinery if under the influence of alcohol or drugs. Read warning labels if taking prescription medicine to determine if your judgment or reflexes are impaired while taking drugs. If there is any doubt, do not operate the machinery or tools.
16. **Maintenance.** For your safety, service and maintenance should be performed regularly by a qualified technician.
17. **Workpiece may be sharp.** After bending or cutting workpieces use caution. Be aware of sharp edges or metal debris of metal that may be created. Use heavy duty gloves when handling the workpiece.
18. **Health and fire hazards.** Understand that the health and fire hazards can vary from material to material. Make sure all appropriate precautions are taken.
19. **Clean-up when finished.** Clean machines and the surrounding area when the operation is finished.
20. **Use proper lock out procedures.** When servicing or cleaning machines, make sure that the machine cannot be started by accident.

DO NOT

- × Do not distract an operator. Horseplay can lead to injuries and should be strictly prohibited.
- × Do not wear loose clothing, gloves, necktie's, rings, bracelets or other jewellery that can be come entangled in moving parts. Confine long hair.
- × Do not handle cuttings by hand because they are very sharp. Do not free a stalled cutter without turning the power off first. Do not clean hands with cutting fluids.
- × Do not use rags or wear gloves near moving parts of machines.
- × Do not use compressed air to blow debris from machines or to clean dirt from clothes.
- × Do not force the machine. It will do the job safer and better at the rate for which it was designed.



BEFORE OPERATING ANY MACHINE, TAKE TIME TO READ AND UNDERSTAND ALL SAFETY SIGNS AND SYMBOLS. IF NOT UNDERSTOOD SEEK EXPLANATION FROM YOUR SUPERVISOR.

MACHINES ARE SAFEGUARDED TO PROTECT THE OPERATOR FROM INJURY OR DEATH WITH THE PLACEMENT OF GUARDS. MACHINES MUST NOT BE OPERATED WITH THE GUARDS REMOVED OR DAMAGED.

2.2 SPECIFIC SAFETY FOR ENGLISH WHEELS

DO NOT use this machine unless you have been instructed in its safe use and operation and have read and understood this manual.



Safety glasses must be worn at all times in work areas.



Close fitting protective clothing or overalls are encouraged



Appropriate protective footwear with substantial uppers must be worn.



Rings and jewellery must NOT be worn in the workshop



Gloves should be worn when handling the work piece



Ear protection should be used in loud and noisy conditions

PRE-OPERATIONAL SAFETY CHECKS

1. Ensure you are familiar with the operation of the English Wheel
2. Check for any damage or parts missing
3. The area around the machine must be clean and free of trip hazards.
4. Any forming die must be inspected for safe use i.e. no cracks.
5. Ensure safety glasses or goggles are available and are worn by all persons in the vicinity.
6. Any test piece, project or material (work piece) to be worked must be of an appropriate thickness and safe to use on this equipment.
7. Faulty equipment must not be used. Immediately check suspect machinery.

OPERATIONAL SAFETY CHECKS

1. Place your test piece, project or material (work piece) securely between the top and bottom dies
2. Do not over reach. Maintain a balanced stance at all times, so that you do not fall or lean against the machine.
3. Use the English Wheel by moving the workpiece in a forward and back action, to slowly work the material.
4. Keep hands and fingers away from the dies.
5. Wear leather gloves when handling the work piece.
6. Use the right tool. Do not force a die set to do a job that it was not designed to do.
7. Give your work undivided attention. Looking around, carrying on a conversation and "horseplay" are careless acts that can result in serious injury
8. DO NOT apply excessive force to the English Wheel.

AFTER OPERATION COMPLETED

1. Clean the machine and place any tools and equipment in the appropriate storage area.
2. Place all scrap or waste in the appropriate bin.

POTENTIAL HAZARDS

- Beware of high forces applied
- Eye injuries – flying or shattering objects
- Pinch and squash
- Laceration injuries

3. SETUP

3.1 UNPACKING

When unpacking, check to make sure that all parts shown in the Parts Diagram are included. If any parts are missing or broken, please contact the distributor

3.2 ASSEMBLY

THE METALMASTER English Wheel will require minor assembly prior to operation. It is important that the entire manual is read to become familiar with the unit BEFORE you assemble and use the Machine. Before assembling the English Wheel, be sure that you have all parts described in the Parts List. (Fig.3.1)

To assemble the machine:

1. Layout the English Wheel components on the floor where the unit will be located and mounted. The floor must be able to support the weight of the English Wheel and the workpieces.
2. Attach the Front Stand (15#) under the Front Tube (16#) so that the mounting holes align. Insert the two Bolts M10 x 85mm (25#) with a M10 washer (24#) from the top. Once the bolts are ready, place the plate (18) over the bolts with a M10 Washers (24#), and then a M10 nut (26#)
3. With the parts laying on the floor, attach the Back Stand (17#) to the main frame (1#) using the two M10 x 80mm bolts with a M10 Washer (24#) on each side of the main frame and secure with a M10 Nut ((26#). Attach the Link Bracket (19#) to the Back Stand (17#) using the two Bolts (35#), M10 x 130mm with a M10 Washers (24#) both sides of the frame, and M10 Nuts (26#). Tighten Nuts and Bolts securely.
4. Attach the assembled front leg (16#, 15#) using the two Bolts M10 x 80mm (23#), with a M10 Washers (24#), on each side of the frame, then M10 nut (26#).
5. Attach the link bracket (19#) to the front leg assembly (16#, 15#) with the two bolts M10 x 85mm (25#) with a M10 washer (24#) both sides of the frame and secured with a M10 nut (26#)
6. With the help of at least two other people, lift the assembled Frame so that it is upright.
7. Securely tighten all assembled frame components.
8. Insert Steel Tube (5#) into the Bottom Die Yoke (8#). Secure with two Screws M8 x 12mm (32#). Place Assembly into the mounting hole in Frame (1#).
9. Screw Knob (4#) into the threaded hole on Frame (1#). Lift and turn Steel Tube (5#) so that the Knob (4#) seats into the slot of Steel Tube (5#). Tighten Knob (4#).

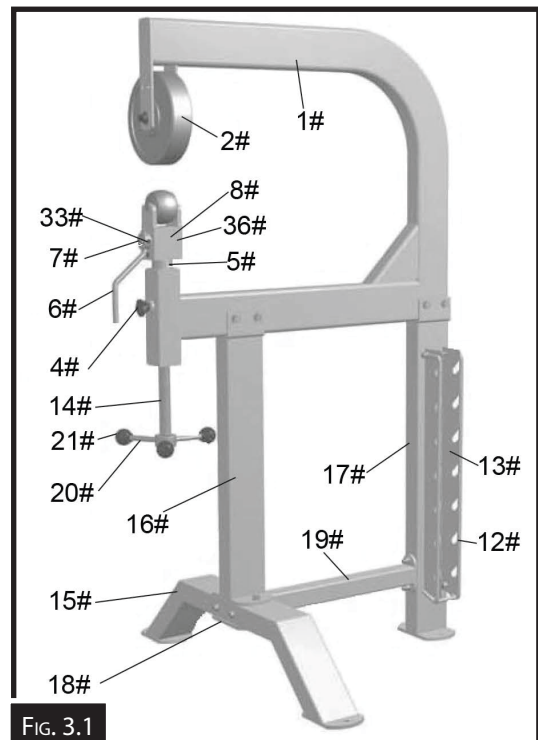

FIG. 3.1

3. SETUP

10. Insert the Eccentric Shaft (7#), with the Handle (6#), into the hole of Bottom Die Yoke (8#).
11. Thread each Handle Lever (20#) into the Thread Rod (14#). and securely tighten. Thread on to the Handle the Balls (21#).
12. Screw Thread Rod (14#) into the bottom of Frame (1#). and into Steel Tube (5#) already installed in Frame (1#).
13. Place the Top Die (2#) with Bearings (9#) on each side, into the top of the Frame (1#). Secure in place with Shaft (3#), Washers M20, and M16mm(22# & 37#),and M16 Nut (31#). Securely tighten.
14. Mount the Bottom Die Rack (13#) to the Back Stand (17#) using two Bolts M8 x 65mm(28#), M8 Washers both sides (29#), and M8 Nuts (30#). Securely tighten.
15. Mount the Lock Bracket (12#) onto the Bottom Die Rack (13#) using M8 x 95mm Bolt (34#), M8 Washer (29#), and M8 Nut (30#). Securely tighten.
16. Install Shafts (10#) in each Bottom Die (11#-01 to 11#-06) with Bearings (9#).
17. Open the Lock Bracket (12#) and place each Bottom Die (11#-01 to 11#-06) on the Bottom Die Rack (13#). Each Bottom Die has its size stamped on it. Place in order of size on the Bottom Die Rack (13#).
18. With the help of two other people, move the assembled English Wheel to the location where it will be mounted to the floor. Measure the size of the mounting holes in the Front Stand (15#) and Back Stand (17#), then drill appropriate size holes in the floor to accommodate the mounting hardware(not supplied).

4. OPERATION

4.1 OPERATIONAL OVERVIEW

The instructions in this section are written with the understanding that the operator has the necessary knowledge and skills to operate this machine.

1. Select the Bottom Die from the Bottom Die Rack (13#), and place on the Bottom Die in the Yoke(8#). When selecting the Bottom Die, consider the type and hardness of the metal being formed as well as the desired curvature of the metal.
2. Insert the workpiece in between the Top Die (2#) and the Bottom Die.
3. Turn the hand wheel (Thread Rod 14#) to raise or lower the Bottom Die Yoke (8#) for an appropriate clearance (or pinching) of the metal between the two dies. It is better to have a loose pinch than a tight one. A tight pinch will make it harder to push the metal through the dies and may cause unwanted creasing. A loose pinch makes it easier to push the metal through the dies, and with more accuracy. It may take more passes to form the metal, however.
4. Turn Knob (4#) clockwise until tight.
5. Begin forming the metal by pushing and pulling it over the dies.
6. If a small adjustment is required between the dies, loosen Knob (4#) and turn the handle (6#). This causes the Eccentric Shaft (7#) to slightly raise or lower the Bottom Die. Tighten Knob (4#) again before proceeding.

4.2 TRACKING PATTERNS

When metal passes between the upper and lower dies, a “track” or shiny line is pressed into the metal. Various tracking patterns can be used to shape workpieces depending upon their shape or size. Bellow are a list of patterns and their use.

Zigzag Pattern

This pattern can be used for a series of forms.(Fig. 4.1)

Note: Try keeping the tracks close to each other in a consistent pattern

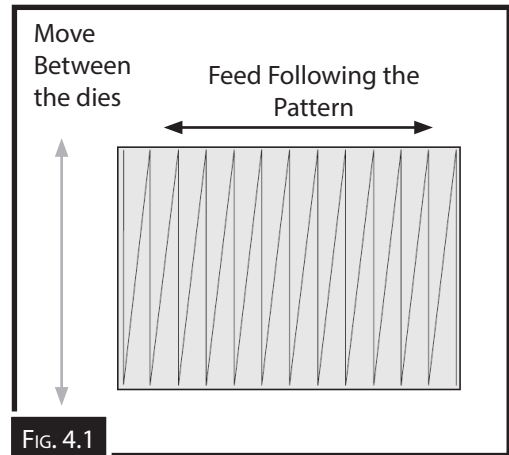

Star Pattern

The star pattern is useful for shaping round workpieces. (Fig. 4.2)

Note: Avoid rolling directly over center of workpiece, as too many passes could overstretch the metal.

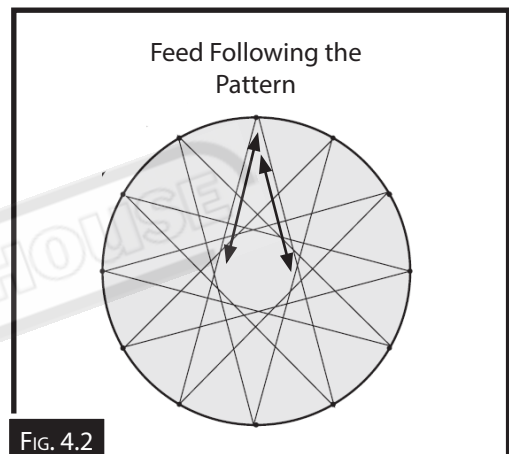

5. MAINTENANCE

5.1 CLEANING AND OILING

When finished with the machine always clean down the machine and oil with a light oil all moving parts and machined surfaces. Inspect the general condition of the tool. Check for loose screws, misalignment or binding of moving parts, cracked or broken parts, and any other condition that may affect its safe operation. If abnormal noise or vibration occurs, have the problem corrected before further use. Do not use damaged equipment.

5.2 MAINTENANCE SCHEDULE

Maintenance Chart						
Maintenance Type	Before Use	After Use	Weekly	Monthly	Every 6 Months	Yearly
Inspect Tools for damage	x					
Wipe off with clean cloth		x	x	x	x	x
Oil moving parts with light oil				x		

SPARE PARTS SECTION

English Wheels Model. EWM-75

Order Code S225

Edition No : EWM-75-1

Date of Issue : 02/2021

The following section covers the spare parts diagrams and lists that were current at the time this manual was originally printed. Due to continuous improvements of the machine, changes may be made at any time without notification.

HOW TO ORDER SPARE PARTS

1. Have your machines **model number, serial number & date of manufacture** on hand, these can be found on the specification plate mounted on the machine
2. A scanned copy of your parts list/diagram with required spare part/s identified.

NOTE: SOME PARTS MAY ONLY BE AVAILABLE AS AN ASSEMBLY

3. Go to www.machineryhouse.com.au/contactus and fill out the inquiry form attaching a copy of scanned parts list.

CONTENTS

Spare Parts Diagram.....	13
Spare Parts List.....	14

SPARE PARTS DIAGRAM

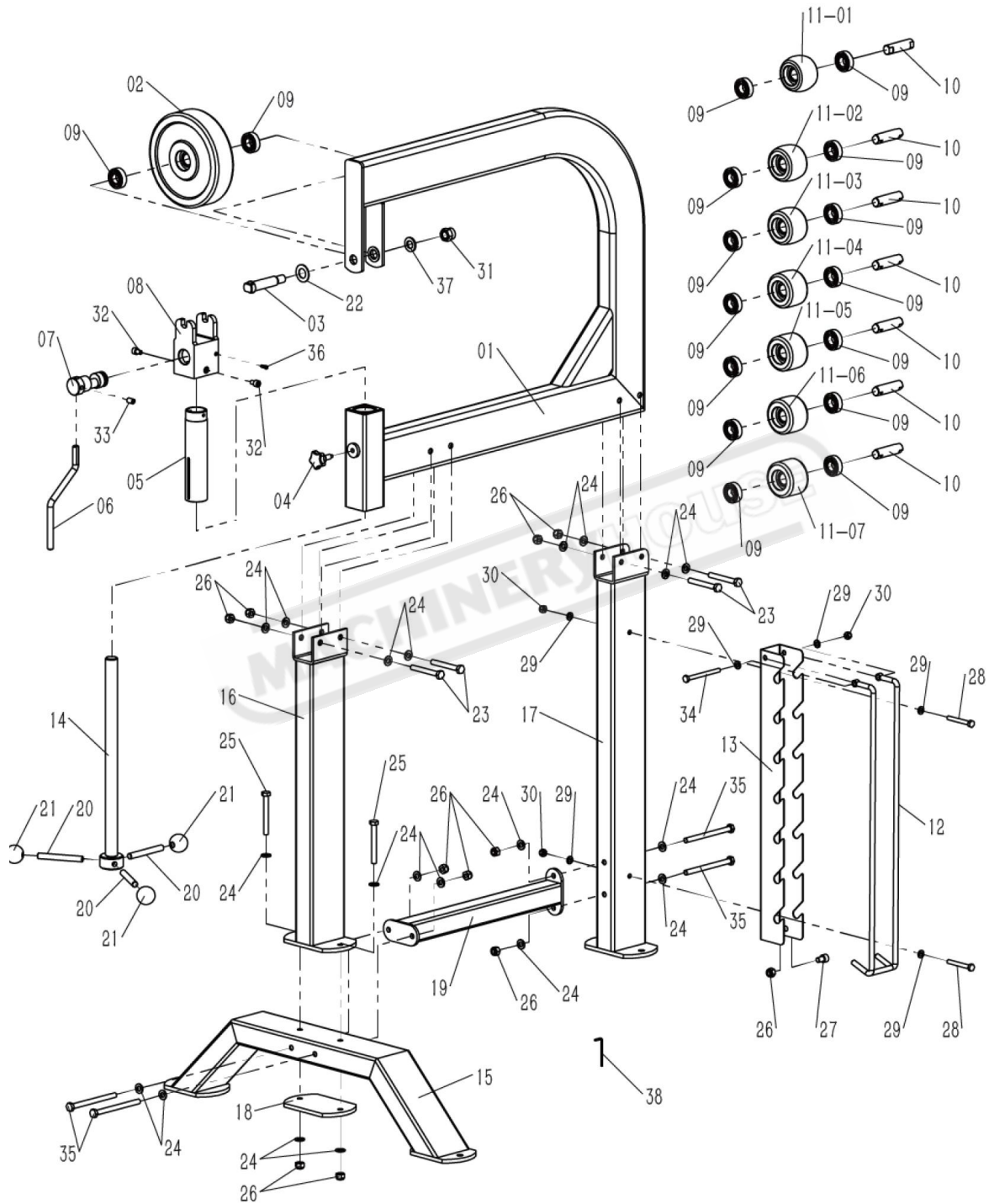

SPARE PARTS LIST

ITEM	DESCRIPTION	QTY.	ITEM	DESCRIPTION	QTY.
1	FRAME	1	17	BACK STAND	1
2	TOP DIE	1	18	PLATE	1
3	SHAFT	1	19	LINK BRACKET	1
4	KNOB	1	20	HANDLE LEVER	3
5	STEEL TUBE	1	21	HANDLE BALL	3
6	HANDLE	1	22	WASHER 20MM	1
7	ECCENTRIC SHAFT	1	23	BOLT M10X80	4
8	BOTTOM DIE YOKE	1	24	WASHER 10MM	20
9	BEARING	16	25	BOLT M10X85	2
10	SHAFT	7	26	NUT M10	11
11-01	BOTTOM DIE 50.8MM/2"	1	27	SCREW M10X15	1
11-02	BOTTOM DIE 76.2MM/3"	1	28	BOLT M8X65	2
11-03	BOTTOM DIE 101.6MM/4"	1	29	WASHER 8MM	6
11-04	BOTTOM DIE 152.4MM/6"	1	30	NUT M8	3
11-05	BOTTOM DIE 203.2MM/8"	1	31	NUT M16	1
11-06	BOTTOM DIE 304.8MM/12"	1	32	SCREW M8X12	2
11-07	FLAT DIE	1	33	SCREW M10X16	1
12	LOCK BRACKET	1	34	BOLT M8X95	1
13	BOTTOM DIE RACK	1	35	BOLT M10X130	4
14	THREAD ROD	1	36	SCREW M4X12	1
15	FRONT STAND	1	37	WASHER 16MM	1
16	FRONT TUBE	1	38	HEX KEY WRENCH 3MM	1

NOTE: SOME INDIVIDUAL PARTS MAY ONLY BE AVAILABLE AS AN ASSEMBLY

WARNING

General Machinery Safety Instructions

Machinery House
requires you to read this entire Manual before using this machine.

- 1. Read the entire Manual before starting machinery.** Machinery may cause serious injury if not correctly used.
- 2. Always use correct hearing protection when operating machinery.** Machinery noise may cause permanent hearing damage.
- 3. Machinery must never be used when tired, or under the influence of drugs or alcohol.** When running machinery you must be alert at all times.
- 4. Wear correct Clothing.** At all times remove all loose clothing, necklaces, rings, jewelry, etc. Long hair must be contained in a hair net. Non-slip protective footwear must be worn.
- 5. Always wear correct respirators around fumes or dust when operating machinery.** Machinery fumes & dust can cause serious respiratory illness. Dust extractors must be used where applicable.
- 6. Always wear correct safety glasses.** When machining you must use the correct eye protection to prevent injuring your eyes.
- 7. Keep work clean and make sure you have good lighting.** Cluttered and dark shadows may cause accidents.
- 8. Personnel must be properly trained or well supervised when operating machinery.** Make sure you have clear and safe understanding of the machine you are operating.
- 9. Keep children and visitors away.** Make sure children and visitors are at a safe distance for you work area.
- 10. Keep your workshop childproof.** Use padlocks, Turn off master power switches and remove start switch keys.
- 11. Never leave machine unattended.** Turn power off and wait till machine has come to a complete stop before leaving the machine unattended.
- 12. Make a safe working environment.** Do not use machine in a damp, wet area, or where flammable or noxious fumes may exist.
- 13. Disconnect main power before service machine.** Make sure power switch is in the off position before re-connecting.
- 14. Use correct amperage extension cords.** Undersized extension cords overheat and lose power. Replace extension cords if they become damaged.
- 15. Keep machine well maintained.** Keep blades sharp and clean for best and safest performance. Follow instructions when lubricating and changing accessories.
- 16. Keep machine well guarded.** Make sure guards on machine are in place and are all working correctly.
- 17. Do not overreach.** Keep proper footing and balance at all times.
- 18. Secure workpiece.** Use clamps or a vice to hold the workpiece where practical. Keeping the workpiece secure will free up your hand to operate the machine and will protect hand from injury.
- 19. Check machine over before operating.** Check machine for damaged parts, loose bolts, Keys and wrenches left on machine and any other conditions that may effect the machines operation. Repair and replace damaged parts.
- 20. Use recommended accessories.** Refer to instruction manual or ask correct service officer when using accessories. The use of improper accessories may cause the risk of injury.
- 21. Do not force machinery.** Work at the speed and capacity at which the machine or accessory was designed.
- 22. Use correct lifting practice.** Always use the correct lifting methods when using machinery. Incorrect lifting methods can cause serious injury.
- 23. Lock mobile bases.** Make sure any mobile bases are locked before using machine.
- 24. Allergic reactions.** Certain metal shavings and cutting fluids may cause an allergic reaction in people and animals, especially when cutting as the fumes can be inhaled. Make sure you know what type of metal and cutting fluid you will be exposed to and how to avoid contamination.
- 25. Call for help.** If at any time you experience difficulties, stop the machine and call you nearest branch service department for help.

WARNING

English Wheel Safety Instructions

Machinery House
requires you to read this entire Manual before using this machine.

- 1. Maintenance.** Make sure all moving parts are locked down before any inspection, adjustment or maintenance is carried out.
- 2. English Wheel Condition.** English Wheel machine must be maintained for a proper working condition. Never operate a English Wheel machine that has damaged or worn parts. Scheduled routine maintenance should performed on a scheduled basis.
- 3. Roll Condition.** Never operate a English Wheel machine with damaged or badly worn Rolls. Replace if required. Rolls should never be greased or lubricated as rolls will slip the material and will not bend.
- 4. Hand Hazard.** Keep hands and fingers clear from moving parts. Serious injury can occur if hand or finger tips get pinched by rolls and can be dragged into machine.
- 5. Gloves & Glasses.** Always wear leather gloves and approved safety glasses when using this machine.
- 6. Avoiding Entanglement.** Tie up long hair and use the correct hair nets to avoid any entanglement with the English Wheel machine moving parts.
- 7. Understand the machines controls.** Make sure you understand the use and operation of all controls.
- 8. Work area hazards.** Keep the area around the English Wheel machine clean from oil, tools, chips. Pay attention to other persons in the area and know what is going on around the area to ensure unintended accidents.
- 9. Guards.** Do not operate this machine without the correct guards in place. Necessary guards protect you from injuries by rolls and moving gears and parts.
- 10. Material condition.** Material must be clean out of oil and dry. Oily material can slip and will not bend.
- 11. Material hardness.** Make sure your hardness is the same throughout the material, we recommend that you use certified material. Never bend hard steel, glass or fragile material on this machine.
- 12. Level machine.** Level the machine on a flat concrete surface by using a spirit level.
- 13. Feeding material.** Making a tight bend in one pass is not possible. So you need several passes before you can achieve a certain radius. Tighter curves and full radius always need more passes.
- 14. Call for help.** If at any time you experience difficulties, stop the machine and call you nearest branch service department for help.

PLANT SAFETY PROGRAM

NEW MACHINERY HAZARD IDENTIFICATION, ASSESSMENT & CONTROL

English Wheel

Developed in Co-operation Between A.W.I.S.A and Australia Chamber of Manufactures
This program is based upon the Safe Work Australia, Code of Practice - Managing Risks of Plant in the Workplace (WHSA 2011 No10)

Item No.	Hazard Identification	Hazard Assessment	Risk Control Strategies (Recommended for Purchase / Buyer / User)
B	CRUSHING	LOW	Secure & support work material. Ensure machine is bolted down.
C	CUTTING, STABBING, PUNCTURING	MEDIUM	Wear gloves to prevent cuts from sharp material.
D	SHEARING	MEDIUM	Keep hands clear from moving parts on rolls.



Plant Safety Program to be read in conjunction with manufactures instructions



www.machineryhouse.com.au



www.machineryhouse.co.nz

Authorised and signed by:
Safety officer: 
Manager: 

Revised Date: 12th March 2012